



# Type SK

## Electric chain hoists SK

Range of electric chain hoists for loads from 60 to 5,000 kg  
Special applications & options

*Special chain hoists for various applications are available:*

- *Fixed hoist*
- *Hoist with manual trolley*
- *Hoist with electric trolley two or variable travelling speed*
- *Hoist with electric trolley short headroom*
- *Hoist with electric articulated trolley*
- *Hoist with manual or electric trolley for ProfileMaster*
- *HandyMaster*



*Electric chain hoist Type SKC  
with electric trolley FNV*



SKD



Type SKB chain hoist  
on ProfileMaster

## Large range of options

Each Type SK electric chain hoist can be fitted with electrical or mechanical optional equipment:

- Stainless steel hoisting chain and hook
- Rain cover
- Explosion proof hoist
- Time meter
- Upper and lower electric limit switch
- "RadioMaster" remote control
- Thermistors on hoisting motor and trolley motor
- Short headroom trolley
- Other power supply voltages 230-380-500 V/50-60 Hz/3 Ph

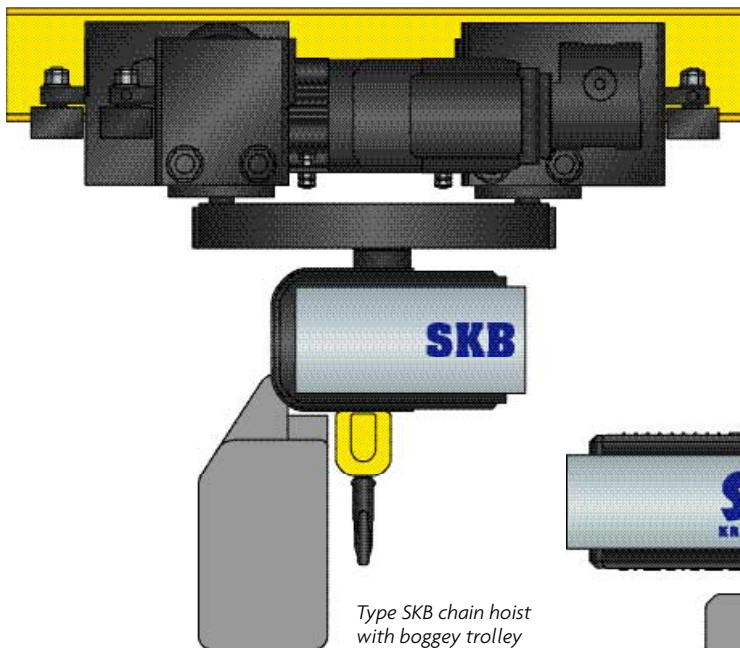

Type SKB chain hoist  
with bogey trolley

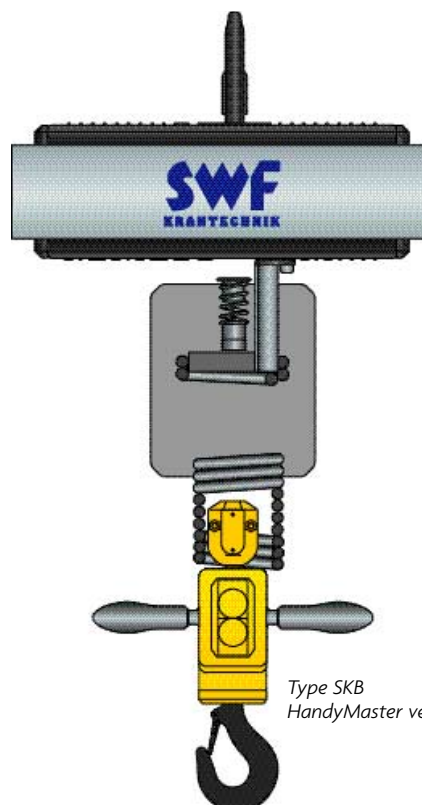

Type SKB  
HandyMaster version



# CRANE KIT

## Components for crane kits

### Application

- *Single girder top running crane for low buildings with minimal headroom*
- *Single girder underslung crane for ceiling installation with minimal headroom*
- *Double girder top running crane for heavy capacity requirements*

### Standard scope of delivery:

- *Electric hoist (rope or chain) with travelling trolley*
- *2 end-carriages with travelling machineries*
- *Electric cubicle for crane*
- *Mobile pendant for all crane movements*
- *Feeding line and brackets for the cable track*
- *Limit switches*
- *Plug and socket connections*

*Single girder top running crane*



*Single girder underslung running crane*

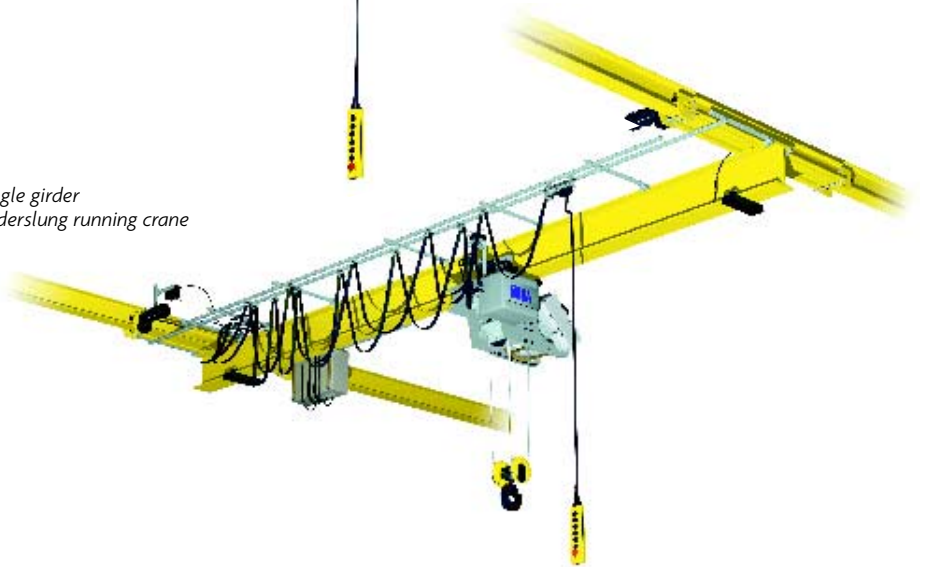

*Double girder top running crane*

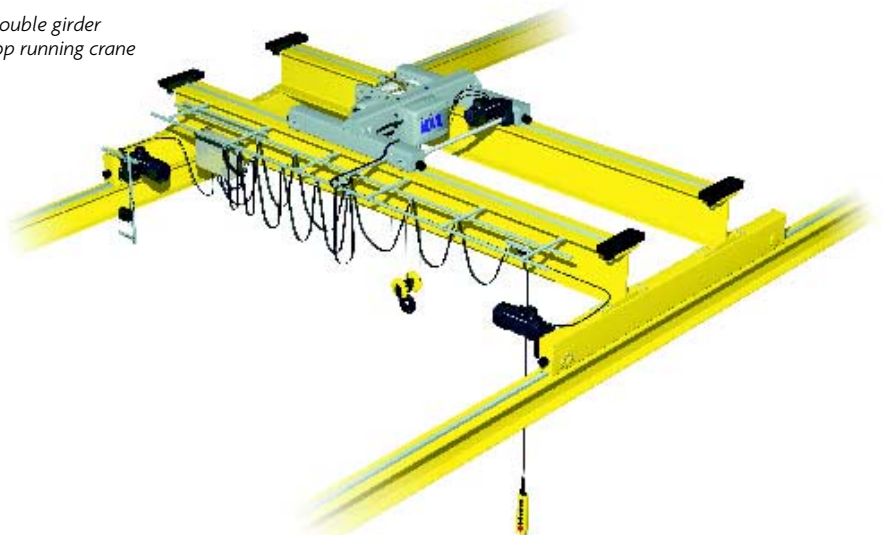



RadioMaster



Crane cubicle



SWF electric wire rope hoist NOVA



SWF electric chain hoist type SK  
for small single girder cranes

## Standard equipment

- Each travelling machinery consists of modular brakemotor (2-speed as standard) and different gearbox combinations. Motors are class F insulated and IP55 protected.
- The tried and tested pendant is well protected against dust and humidity and designed for heavy duty applications. All connections with plug and socket.
- For freedom of movement, safety of operation the standard pendant can be replaced by remote control "RadioMaster".
- Feeding line and brackets for the cable track. Power supply for the hoist, trolley and the pendant are always chosen to match the crane and hoist configuration. All the necessary connecting elements are supplied. Flat cable, cable trolley and plugs are pre-assembled.
- Crane cubicle in IP55 protection.

Complete range of top and underslung end-carriages

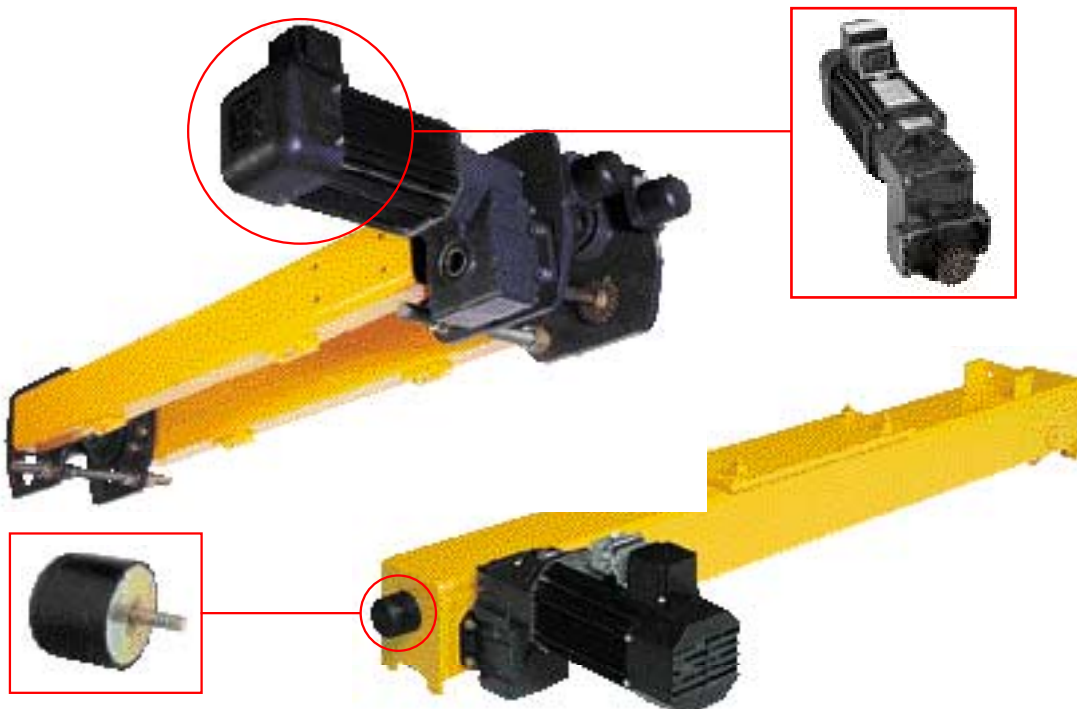



# PROFILE MASTER

Modular overhead handling system for loads from 125 to 2,000 kg

## Application

The ProfileMaster is a light crane system designed for ware house or manufacturing

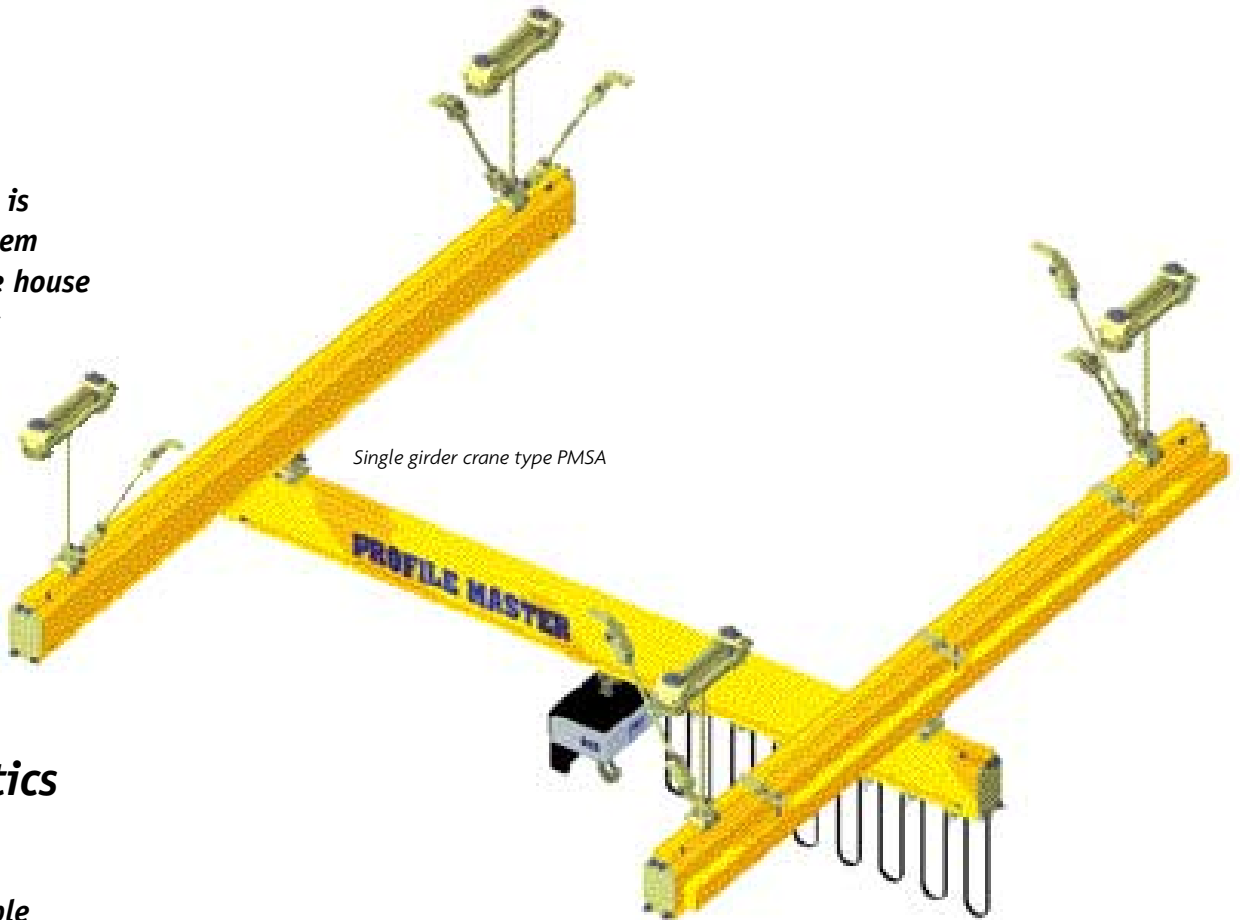

Single girder crane type PMSA

## Technical characteristics

The ProfileMaster track is based on a modular principle from 125 to 2,000 kg capacity



Double girder crane

Example of ProfileMaster installation in a ware house



## Technical characteristics

ProfileMaster is available in 3 different types of profile, which are determined by the load capacity and the distance between suspension points:

- UKA 20
- UKA 30
- UKA 40

Load capacity from 125 to 2,000 kg.

The system is based on a special profile, which is manufactured from a metal sheet in order to obtain an extremely smooth and regular surface. The closed structure makes it possible to keep the inside clean.

The strong profile allows important suspension distances.

Crane bridge and trolleys run silent and smooth.

A wide variety of trolleys and drives are available.

The modular system allows to realise the right solution to your application. Switches, turntables and other components are available.



UKA 20

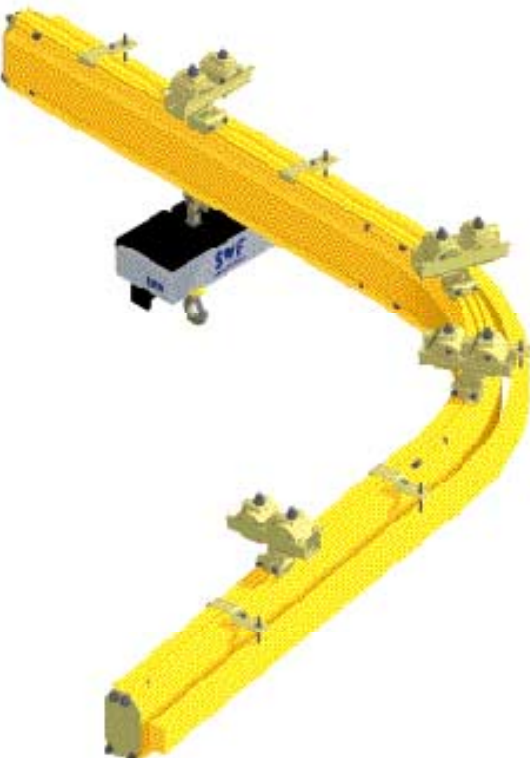

Monorail available in straight and curved version

UKA 30

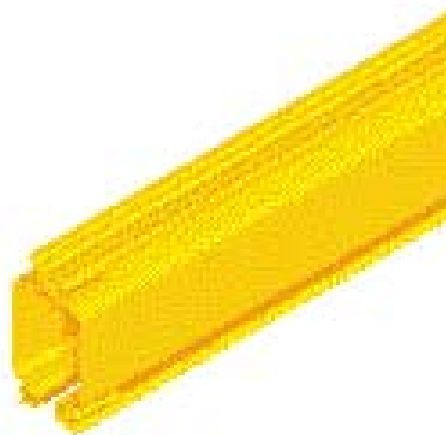

UKA 40

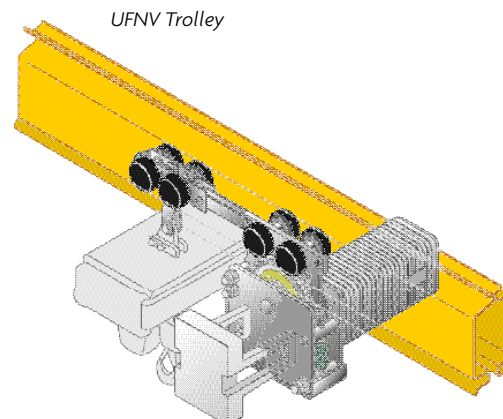

UFNV Trolley



# EX

## EX lifting equipment

Range of explosion proof lifting equipment for loads from 125 to 25,000 kg

*Explosion proof electric wire rope hoist*

### **Application:**

- *The Explosion proof lifting equipment provides a solution for any industry which must work in an explosion hazard atmosphere (Chemical, Petrochemical Industry, Steel, Nuclear, Pharmacy, Food Industry, Power Stations, Electronic Industry, etc...)*
- *Also available as complete "Crane Kit"*

### **Technical characteristics:**

*Explosionproof hoists for explosion hazard atmospheres of the groups:*

- *EEx de IIB T1 to T4*
- *EEx de IIC T1 to T4*



Explosion proof electric belt hoist for loads from 500 up to 2,000 kg



Explosion proof electric chain hoist for loads from 125 to 5,000 kg



SWF Electric Explosion proof hoists comply with the regulations from the European Federation for Handling "FEM" and are built according to the official regulation of the European Committee for Electrotechnical Standardization, the "CENELEC" standards:

- EN 50014
- EN 50018
- EN 50019

Each SWF EX hoist is manufactured with explosion protection according to EEx de IIB T4 degree (EN/DIN) but as an option the protection level can be IIC and the hoist can be equipped with spark proof features.

### Definition of the group

Groups	Medium
<b>I</b>	<ul style="list-style-type: none"> <li>• Methane</li> </ul>
<b>IIA</b>	<ul style="list-style-type: none"> <li>• Acetone</li> <li>• Butyl Alcohol</li> <li>• Ethyl Alcohol</li> <li>• Ethyl Acetate – Methanol</li> <li>• Butane – Propane – Hexane</li> <li>• Ammonia – Blast furnace gas</li> <li>• Carbon Monoxide – Pentane</li> <li>• Heptane – Iso Octane – Decane</li> <li>• Benzene – Xylene</li> <li>• Cyclohexane – Ethyl – Methyl</li> <li>• Ketone – Methyl Acetate</li> <li>• n propyle Acetate – n butyle Acetate – Amyle Acetate</li> <li>• Chloromethylene – Isobutenol – Amyl Alcohol – Ethyl Nitrite</li> </ul>
<b>IIB</b>	<ul style="list-style-type: none"> <li>• Ethylene – Butadien 1.3</li> <li>• Diethyl Ether – Ethylene Oxyd – Town gas – Coke oven gas</li> </ul>
<b>IIB</b>	<ul style="list-style-type: none"> <li>• Hydrogen – Carbon di Sulphide CS2</li> <li>• Acetylene C2 H2</li> </ul>

Classification of the maximum material surface temperatures indicated in the user class designation :

T1 - 450°C / T2 - 300°C / T3 - 200°C  
 T4 - 135°C / T5 - 100°C / T6 - 85°C

# A world-wide network

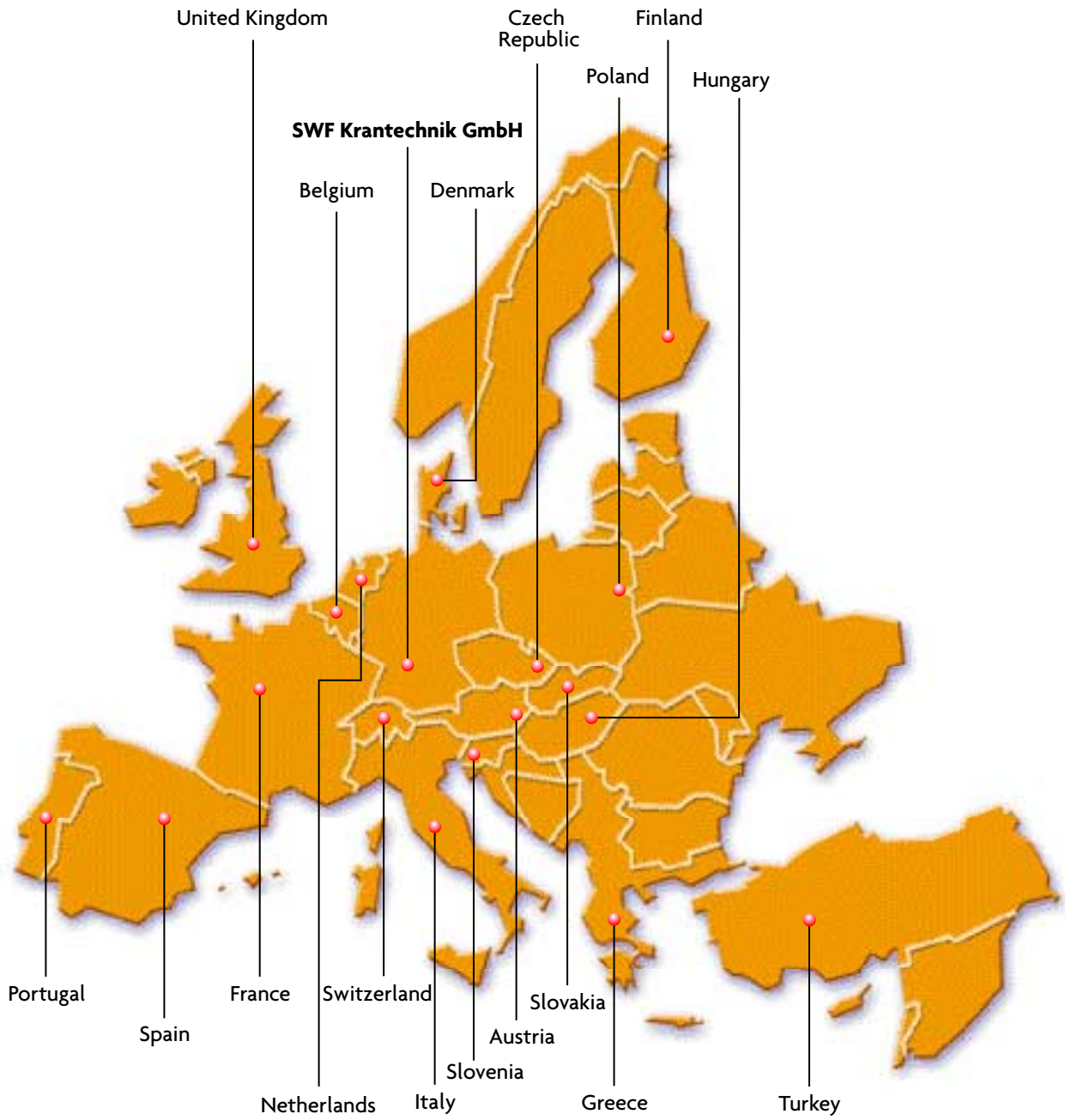

# Fax

Please copy and fax to  
+49 (0) 621 - 78 99 01 00



Company : \_\_\_\_\_

Name : \_\_\_\_\_

Function : \_\_\_\_\_

Address : \_\_\_\_\_

\_\_\_\_\_

Phone : \_\_\_\_\_ Fax : \_\_\_\_\_

E-mail : \_\_\_\_\_

**We are interested in the following technical material:**

- Electric wire rope hoists
- Electric chain hoists
- Crane Kit
- ProfileMaster
- Ex lifting equipment
  
- .....
- Please contact us for an appointment. We are looking forward to your call!



SWF Krantechnik GmbH  
P.O. Box 310 410 - D-68264 Mannheim  
Boehringer Strasse 4 - D-68307 Mannheim  
Tel.: +49 (0) 621 - 78 99 00 - Fax: +49 (0) 621 - 78 99 01 00  
[info@swfkrantechnik.com](mailto:info@swfkrantechnik.com)  
[www.swfkrantechnik.com](http://www.swfkrantechnik.com)



SWF Krantechnik GmbH  
P.O. Box 310 410 - D-68264 Mannheim  
Boehringer Strasse 4 - D-68307 Mannheim  
**Tel.: +49 (0) 621 - 78 99 00 - Fax: +49 (0) 621 - 78 99 01 00**  
**info@swfkrantechnik.com**  
**www.swfkrantechnik.com**